

NOTES:

- 1.) DIMENSIONS SHOWN ARE IN INCHES [MILLIMETERS].
- 2.) DRAWING SHOWS MAIN COMPONENTS ONLY. DRAWING TO BE USED TO SHOW SYSTEM LAYOUT ONLY.
- 3.) TOTAL WEIGHT OF SYSTEM WILL VARY BASED ON CUSTOMER'S SITE CONDITIONS AND COMPONENT SPECIFICATIONS. TOTAL WEIGHT OF SYSTEM MAY VARY ANYWHERE BETWEEN 13,200 - 13,400 LBS. [5,988 - 6,078 Kg]

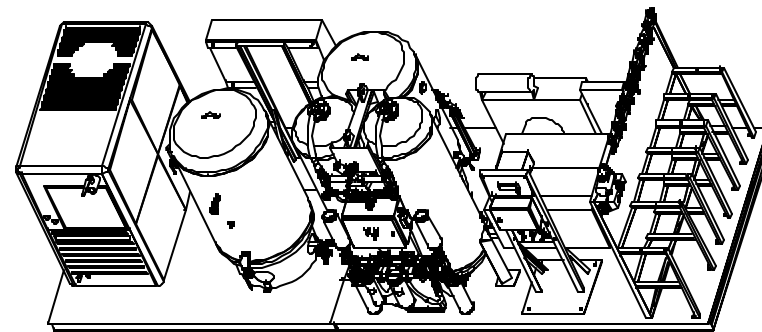

SCALE 0.047

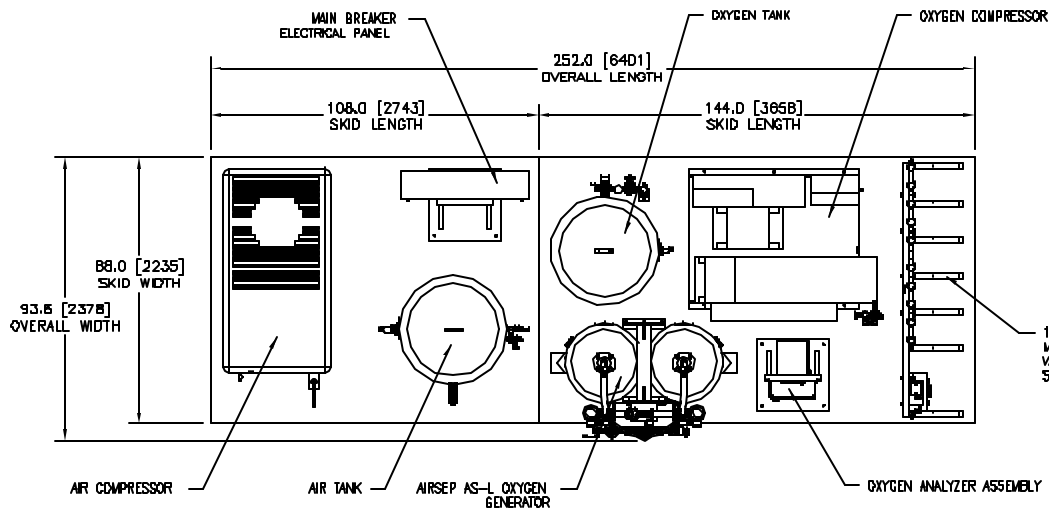
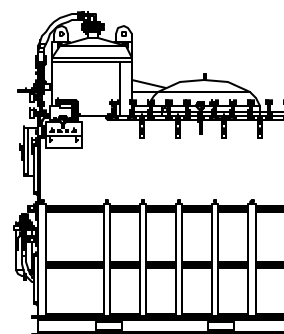
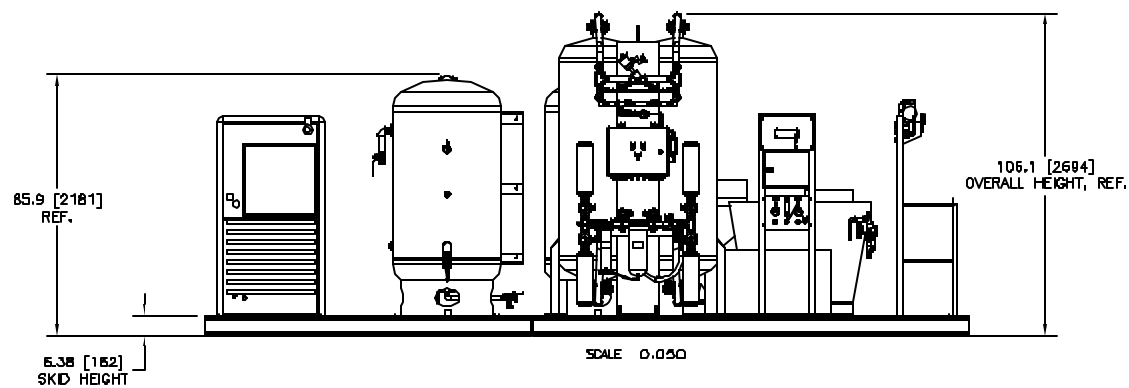

DRAWING SUBJECT TO CHANGE WITHOUT NOTICE

REV	REVISION	ECN #	BY	DATE	APP'D

APPROVAL	DATE	
DESIGNED	03/01/08	
		ASL1000CR(O) CYLINDER FILLING TYPICAL PLANT LAYOUT
		W/A ASL1000CR 1.000 SHEET 1 OF 1

# AIRSEP ASL1000NCR(M) CYLINDER FILLING PLANT TYPICAL PLANT LAYOUT

